



POWER JOINT™ WELD PACKAGE

FOR ROBOT TYPES WITH INNER CABLE DRESS



SOLUTIONS FOR: ABB // FANUC //
KUKA // MOTOMAN

POWER JOINT™ WELD PACKAGE: DCT POWER SOURCE // WELD PROCESS CONTROLLER //
ROBOT INTERFACE // WIRE FEEDER// WIRE GUIDANCE // CABLE BUNDLE // CONTROL CABLE //
TORCH SYSTEM // GOOSENECKS // CONSUMABLES

SKS WELD PACKAGE: SYSTEM DESIGN

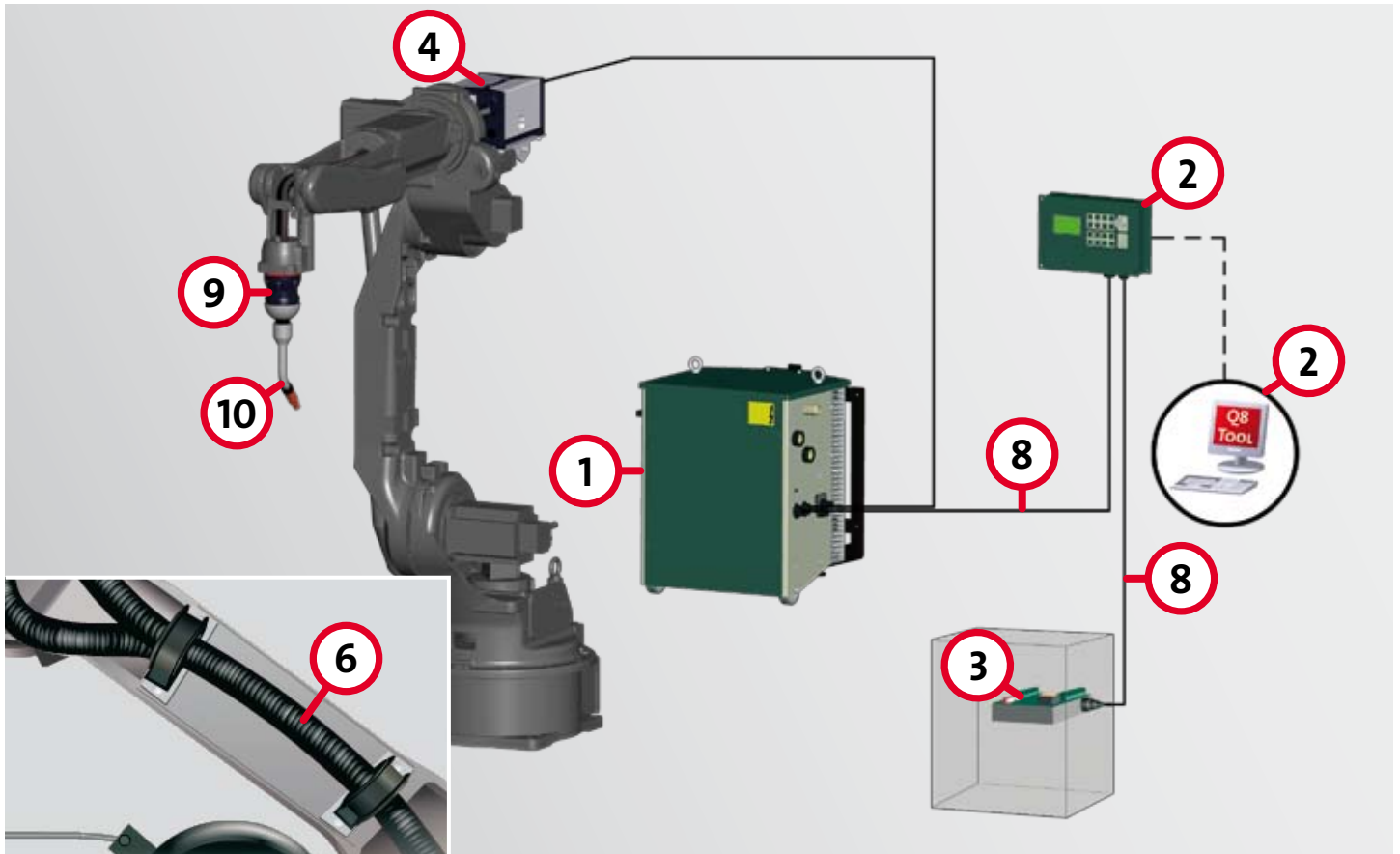

SKS WELD PACKAGE COMPONENTS: OVERVIEW



1 DCT POWER SOURCE

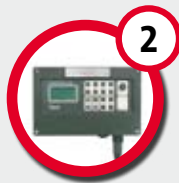

2 WELD PROCESS CONTROLLER + SOFTWARE

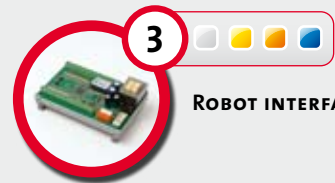

3 ROBOT INTERFACE



4 WIRE FEEDER



5 WIRE GUIDANCE

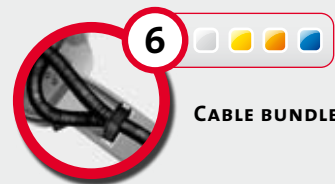

6 CABLE BUNDLE



7 GROUND CABLE



8 CONTROL CABLE

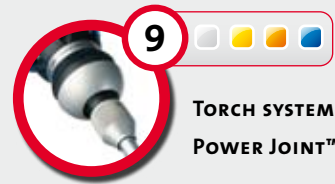

9 TORCH SYSTEM POWER JOINT™



10 GOOSENECKS/ CONSUMABLES

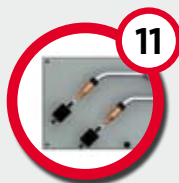

11 TCP DRAWING/ CHECKING FIXTURE/ GAS NOZZLE DIMENSIONS

SKS POWER JOINT™ WELD PACKAGE







The Original.

SKS Weld Package.

For all industrial robots with inner cable dress.

Torch system Power Joint™: Endless rotation

This brochure contains information about the SKS Weld Package, the torch system **POWER JOINT™**, as well as consumables and spare parts. There are various features of the welding machine components and torch systems available depending on the robot system and the welding task.

The **POWER JOINT™ WELD PACKAGE** can be used with common industrial robots. Please look for color coding to specify the robot types **ABB**, **FANUC**, **KUKA** and **MOTOMAN** (   ).



THE COMPLETE SKS POWER JOINT™ WELD PACKAGE IS DESIGNED FOR THE FOLLOWING WELDING PROCESSES, MATERIALS AND POWER RANGE:

Processes: MIG/MAG (GMAW)

Materials: Fe, CrNi, Al, CuSi

Wire diameter: 0.8-1.6 mm

Max. power: 420 A - 60 % duty cycle/40 °C, air-cooled



POWER SOURCE LSQ5

LSQ5 POWER SOURCE WITH DIRECT CONTROL TECHNOLOGY DCT

The LSQ5 ensures the optimum arc energy. It uniquely adjusts to different weld processes. Unlike conventional power sources with inverter technology, the LSQ5 with Direct Control Technology controls its switching transistors without any fixed clock frequency according to the needs of the weld process. Without any delay, the energy needed for the process is provided instantly. The flexible fine tuning is done by a central processor. The CPU continuously analyzes the weld process and current/voltage values on the basis of data obtained and optimally drives the switching transistors of the power section. This results in an extremely high efficiency and a low temperature development. The power source can be configured with only two buttons and four LED indicators. For world-wide usage, voltages can be configured without opening the power source.

ALTERNATIVE



LSQ3 POWER SOURCE WITH DIRECT CONTROL TECHNOLOGY (DCT)

The LSQ3 offers enough power reserves for special weld tasks like chassis and exhaust parts and other thin sheet metal applications. LSQ3: 340 A at 60 % duty cycle, 3 x 400 V
LSQ3A: 340 A at 60 % duty cycle, 3 x 480 V

OVERVIEW OF POWER SOURCES

DESCRIPTION	PART-NO.
LSQ5	77-1185-00
LSQ3	77-1184-00
LSQ3A	77-1184-10

THE MAIN BENEFITS ARE:

DCT provides a speed regulation up to ten times higher compared to conventional inverter technology. This leads to excellent control behavior and shorter response times.

The weld properties are substantially improved. Software replaces hardware: Fewer components also increase the reliability in continuous operation.

SPECIFICATIONS:

DESCRIPTION	LSQ5	LSQ3	LSQ3A
Performance	420 A - 60 % duty cycle/40 °C	340 A - 60 % duty cycle/40 °C	340 A - 60 % duty cycle/40 °C
Processes	MIG/MAG (GMAW)		
Weight	49 kg	37 kg	37 kg
Primary voltage	3 x 400 (480) V	3 x 400 V	3 x 480 V
Wall mounting	Yes (optional)	Yes (integrated)	Yes (integrated)
Conformities	CE, CSA, UL	CE	CE
Dimensions L/W/H	450 x 400 x 540 mm	450 x 330 x 540 mm	450 x 330 x 540 mm

OPTION



WALL MOUNT FOR LSQ5

Space-saving design that makes for easy cleaning/maintenance.

LSQ5 OPTION

DESCRIPTION	PART-NO.
Wall mount	77-1180-01

Innovative Control Concept with Touch Screen.

With the new Q84 up to four weld machines can be controlled centrally.



Weld Process Controller Q84

The new Q84 is equipped with a 10 inch touch screen, an innovative usability concept and an advanced visualization technology for much easier operating. The user interface has the look and feel of the Q8Tool4 software. The real weld controllers are in card slots in the Q84. This new weld controller concept can host up to four Q81 weld process controller cards. Every single Q81 card can independently control a weld machine.

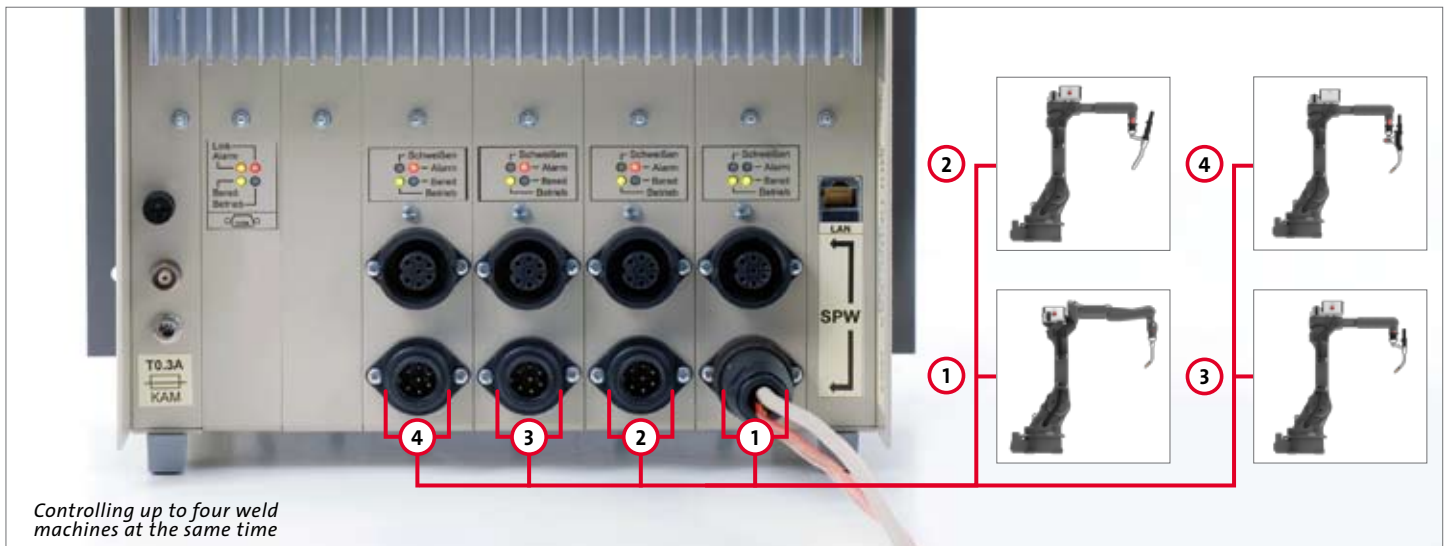

Controlling up to four weld machines at the same time



WELD PROCESS CONTROLLER Q84

The universal weld process controller Q84 calculates the optimal parameters for each welding process. Only basic data such as material, wire type, wire feed speed and type of gas must be entered.

Processes/features: MIG/MAG (GMAW), I-Pulse, U-Pulse, KF-Pulse, Synchronweld™, RWDE™, NWDE™
 Programs: 992 (x4)

General functions: Display and saving of readings, alarms

Monitoring functions: Weld current monitoring, auto compensation, arc and ignition monitoring, motor current, gas and water monitoring

Easy to network via Ethernet: Traceability

Ports: RJ45-Ethernet, SPW-Bus, micro SD

Remotote Control/Administration: Q8Tool, VNC client

OVERVIEW WELD PROCESS CONTROLLER

DESCRIPTION	PART-NO.	PLEASE NOTE:
Q84 with 1 Q81 weld process controller card	77-7240-10	The Q84 can be equipped with up to four Q81 weld process controller cards.
Q84 with 2 Q81 weld process controller cards	77-7240-20	
Q84 with 3 Q81 weld process controller cards	77-7240-30	
Q84 with 4 Q81 weld process controller cards	77-7240-40	

OVERVIEW Q84 MOUNTING KITS

DESCRIPTION	PART-NO.
Mounting on Power Source LSQ5	77-7240-01
Wall mounting	77-7240-02

ALTERNATIVE



WELD PROCESS CONTROLLER Q8PT



WELD PROCESS CONTROLLER Q8PW

Same functionality as Q8pt but in a wall mount version (-w)

WELD PROCESS CONTROLLER Q8PT AND Q8PW

The Q8pt is the alternative to the Q84. It has the same functionality/features as a single weld card of the Q84. The illuminated LCD display shows clearly all parameters and values needed for the weld task or program selection.

Processes/features: MIG/MAG (GMAW), I-Pulse, U-Pulse, KF-Pulse, Synchronweld™, RWDE™, NWDE™

Programs: 992

General functions: Display and saving of readings, alarms

Monitoring functions: Weld current monitoring, auto compensation, arc and ignition monitoring, motor current, gas and water monitoring

Easy to network via Ethernet: up to traceability

Ports: RS232, USB, RJ45-Ethernet, SPW-Bus

OVERVIEW WELD PROCESS CONTROLLER

DESCRIPTION	PART-NO.
Q8pt	77-7210-00
Q8pw	77-7220-00



WELD PROCESS CONTROLLER Q6PW



WELD PROCESS CONTROLLER Q4

Weld Process Controller Q4 as integrated solution into the power source

WELD PROCESS CONTROLLER Q6PW AND Q4

The perfect solution for local administration – the weld process controllers Q6pw and Q4 provide all basic functions as the Q8pt or the Q8pw. The controllers can be administrated over the USB port with the Q8TOOL4 software. As a small and compact solution for the cost-optimized application, the Q4 is integrated into the power sources LSQ3 or LSQ5.

Processes/features: MIG/MAG (GMAW), I-Pulse, U-Pulse, KF-Pulse, Synchronweld™, RWDE™

Programs: 992

General functions: Display and saving of readings, alarms

Monitoring functions: Weld current monitoring, auto compensation, arc and ignition monitoring, motor current, gas and water monitoring

Ports: RS232, SPW-Bus (Q6pw only), USB

OVERVIEW WELD PROCESS CONTROLLER

DESCRIPTION	PART-NO.
Q6pw	77-7230-00
Q4/LSQ5	77-1185-20
Q4/LSQ3	77-1184-20
Q4/LSQ3A	77-1184-30

PLEASE NOTE: The Q4 Weld Process Controller is integrated into the front of the power source and is delivered with the power source.



Q8TOOL SOFTWARE

The Q8Tool software provides accurate and comprehensive process monitoring. The user can store weld parameters for documentation on a PC and/or administrate them. It offers basic functions such as reading, modifying and documenting of weld parameters. Additionally, new weld parameters can be created and transferred to the universal weld control Q8pt/w. The Q8pt/w weld data is portable and the installation of further control units on new equipment is easy. Also, the software allows reading and exporting of measurements and alarms. Graphical and numerical recording of measures helps defining and optimizing parameters for new parts. Users have a powerful tool for analyzing and documenting their weld results.



NETWORK

The weld controller units can easily be networked via Ethernet ports: Time savings through centralized administration of all controllers within the corporate network. There is a central backup of all welding parameters, management of user rights and access, process monitoring up to traceability. The Q8Tool software is provided free of charge with the Q8 series weld controller. No additional hardware or software is required.

Perfect integration.

Interfacing all industrial robot types.

A



OR

B



Interface UNI 5 / FB5

With the universal interface solution from SKS, weld controllers can be connected with all industrial robot types. Users basically have two options for connecting robots with weld controllers: The connection can be realized with the SKS interface UNI 5 or by integrating into a given field bus environment with a field bus solution.

STANDARD APPLICATION

Robot controllers or overall system controllers (e.g. PLC) use digital or analog signals to communicate with the SKS weld controller. The interface UNI 5 translates these signals for the SKS welding machine. With just one interface, a variety of digital encodings and analog levels can be processed. The interface UNI 5 comes with a preconfigured connection kit for easy installation.

FIELD BUS APPLICATION

Field bus systems exchange signals via serial communication. The field bus master, usually the robot controller or overall system controller, bundles and processes the signals of the connected field bus, including the welding machine. Standard field bus systems are e.g., Interbus-S, Profibus DP or Device-Net. The SKS field bus interface FB5 translates the field bus signals for the SKS welding machine using a standardized protocol. It makes no difference which type of field bus system is used. The signals are always at the same place on the field bus. This makes the preparation of the robot or system controller much easier.

A



OPTION



SYNCHROWELD™ unites the weld system and robot by a communication protocol (RWDE™). This technology allows the weld system to get the actual robot speed and automatically adjusts the weld parameters accordingly. The result is a constant energy per unit length. At the same time, the programming effort can be significantly reduced.

ROBOT INTERFACE UNI 5

The interface connects the welding equipment with all industrial robot types. With its high degree of standardization, the UNI 5 is the perfect choice for connecting the weld controller (e.g. Q8pt/w) with an industrial robot. The UNI 5 comes preprogrammed and configured for different robot types. Configuration to a particular robot type is handled easily by programming the interface with two buttons for the given robot type.

OVERVIEW OF ROBOT INTERFACES

 FOR ROBOT TYPE-ABB

DESCRIPTION	PART-NO.
UNI 5A FOR IRC5	77-8011-08

 FOR ROBOT TYPE-FANUC

DESCRIPTION	PART-NO.
UNI 5A FOR RJ3iC	77-8001-84

 FOR ROBOT TYPE-KUKA

DESCRIPTION	PART-NO.
UNI 5A FOR KR C2	77-8011-08

 FOR ROBOT TYPE-MOTOMAN

DESCRIPTION	PART-NO.
UNI 5C (Synchronweld™ over RS232) FOR NX 100 / DX 100	77-8013-00

ALTERNATIVE

B



FIELD BUS CONNECTION

Various field bus types are supported (e.g. Profibus DP, DeviceNet). The field bus interface has drilled bore holes for flexible mounting within the weld cell. Two additional mounting kits provide easy installation at the power source or into the cabinet. Additionally, external power can be connected to the interface. More details on SKS solutions for the specific field bus types are available on request.

OVERVIEW FB 5 INTERFACES

DESCRIPTION	PART-NO.
Interbus-S (copper line)	77-3-1
Profibus DP	77-3-2
DeviceNet	77-3-3

CABINET MOUNTING

DESCRIPTION	PART-NO.
Mounting kit for cabinet	77-1182-02
Control cable with bracket	77-3102-02

POWER SOURCE MOUNTING

DESCRIPTION	PART-NO.
Mounting kit for power source	77-1182-03

OPTIONAL POWER SUPPLY (24V)

DESCRIPTION	PART-NO.
Connection cable 2.0m (with open ends)	77-1182-04



WIRE FEEDER PF5 LEA

Smaller and with less weight accompanied by improved efficiency over conventional wire feeders the PF5 goes along with the steady development of arc welding robots. Modern motor, gear and control technology provide a strong performance and highest possible precision. The robust plastic housing is electrically insulated. As a "lightweight" is the PF5 the perfect choice for the new generation of robots with inner cable dress.

OPTION



GAS PRESSURE MONITORING

OVERVIEW PF5

DESCRIPTION	PART-NO.
PF5 LEA	10-2-9
Gas pressure monitoring	10-2-0-70

TECHNICAL DATA

Weight	3.8 kg
Motor	70W
Wire feeding speed	2.5 - 25 m/min
Roll diameter	0.8 - 1.6 mm

CENTER GUIDES

Available in two versions:
For steel or aluminum wires

OVERVIEW OF CENTER GUIDES

DESCRIPTION	PART-NO.
Wire- ϕ < 2 mm for steel wire	12-2-1-15
Wire- ϕ 0.8-1.0 mm for aluminum	12-2-1-17
Wire- ϕ 1.2-1.6 mm for aluminum	12-2-1-19

DRIVE ROLL FOR WIRE FEEDER

For wire diameters 0.8-1.6 mm and groove-types (V-groove for steel and U-groove for aluminum wires)

OVERVIEW OF FOUR ROLLER DRIVE ROLLS

DESCRIPTION	PART-NO.
Wire- ϕ 0.8 mm, V-groove	12-2-3-08
Wire- ϕ 0.9 mm, V-groove	12-2-3-09
Wire- ϕ 1.0 mm, V-groove	12-2-3-10
Wire- ϕ 1.2 mm, V-groove	12-2-3-12
Wire- ϕ 1.4 mm, V-groove	12-2-3-14
Wire- ϕ 1.6 mm, V-groove	12-2-3-16
Wire- ϕ 1.0 mm, U-groove	12-2-3-110
Wire- ϕ 1.2 mm, U-groove	12-2-3-112
Wire- ϕ 1.6 mm, U-groove	12-2-3-116



PRESSURE ROLL

Pressure roll for wire feeder

PRESSURE ROLL

DESCRIPTION	PART-NO.
Pressure roll	12-2-3-0



WIRE FEEDER BRACKETS

Wire feeder bracket for PF5 with holes and screws for installation

OVERVIEW OF WIRE FEEDER BRACKETS

FOR ROBOT TYPE-ABB

DESCRIPTION	PART-NO.
IRB1600 iD	14-2-5

FOR ROBOT TYPE-FANUC

DESCRIPTION	PART-NO.
ARC MATE 100iC / 100iC/6L / 120iC / 120iC/10L	14-4-4

FOR ROBOT TYPE-KUKA

DESCRIPTION	PART-NO.
KR5 ARC HW	14-3-5
KR16 ARC HW	14-3-6

FOR ROBOT TYPE-MOTOMAN

DESCRIPTION	PART-NO.
MA1400	14-1-5
MA1800 / MA1900	14-1-13

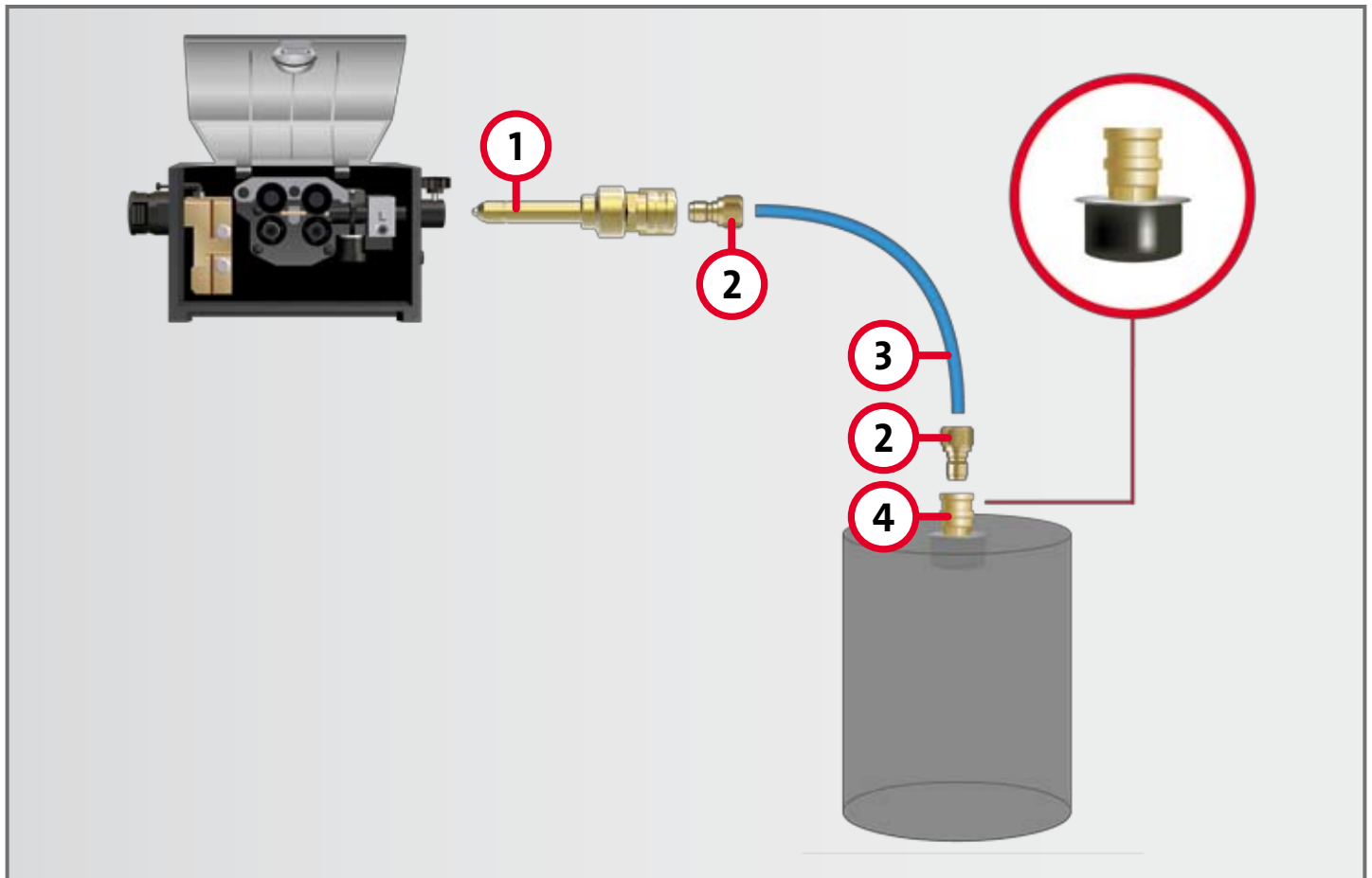

- ① Wire inlet body with quick coupling at wire feeder
- ② Connector for polymer conduit
- ③ Polymer conduit
- ④ Drum connector

With the new SKS polymer guidance, the high efficiency of the whole system extends up to the drum.

ADVANTAGES OF POLYMER WIRE GUIDANCE

Extraordinary good glide properties reduces motor load

Minimized abrasive wear and reduced dirt in wire feeder and torch system

Lightweight design and a high inherent stability for easy installation

Length can be freely chosen by the customer

Cost optimized exchange: only the polymer conduit must be changed, connectors are reusable.

Optimized materials for longer life and reduced downtimes

ALTERNATIVE



WIRE INLET BODIES FOR ADDITIONAL SYSTEMS

Beside the wire inlet body for the SKS wire guidance, inlet bodies for additional systems are available.

OVERVIEW OF WIRE INLET BODIES FOR ADDITIONAL SYSTEMS

DESCRIPTION	PART-NO.
M10 with internal thread for ESAB	10-2-0-50
UNF 3/8x24" with external thread	10-2-0-51
with 9.6 mm bore hole	10-2-0-52
with 13 mm bore hole	10-2-0-53
with PG9 thread	10-2-0-56
with 1/4" internal thread	10-2-0-60

1

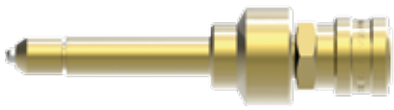
**WIRE INLET BODY WITH QUICK COUPLING**

Wire inlet body for PF5 with quick coupling

WIRE INLET BODY WITH QUICK COUPLING

DESCRIPTION	PART-NO.
Wire inlet body with quick coupling	10-2-0-61

2

**CONNECTOR FOR POLYMER CONDUIT**

Connection nipple for polymer conduit

CONNECTOR FOR POLYMER CONDUIT

DESCRIPTION	PART-NO.
Connector for polymer conduit	44-40-3

PLEASE NOTE: Two connectors necessary.

3

**POLYMER WIRE CONDUIT**

Polymer wire conduit (sold by meter)

POLYMER WIRE CONDUIT

DESCRIPTION	PART-NO.
Polymer wire conduit, blue	44-9-1

4

**CONNECTOR FOR WIRE DRUM**

Quick connector with ceramic-inlet

CONNECTOR FOR WIRE DRUM

DESCRIPTION	PART-NO.
Connector for wire drum	44-40-1



CABLE BUNDLES: POWER SOURCE TO WIRE FEEDER PF5

Coaxial power cable 72 mm² with internal gas flow, control cable L-700, disconnect cable, corrugated tube and cable holder. Air-cooled version.

OVERVIEW OF CABLE BUNDLES

LENGTH	PART-NO.
5 m	20-4-5
7 m	20-4-7
10 m	20-4-10
12 m	20-4-12
15 m	20-4-15
20 m	20-4-20

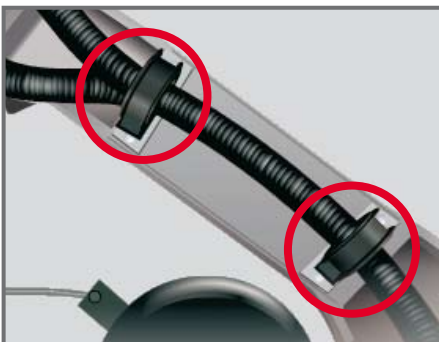

MOUNTING CABLE BUNDLE: CLAMPING SET

Provides perfect installation of the cable bundle for all different robot types. Undefined cable movements are prevented. This results in higher lifetime.

OVERVIEW OF CABLE BUNDLE CLAMPING SETS

FOR ROBOT TYPE-ABB

MODEL	PART-NO.
IRB1600	91-3-0-41-10

FOR ROBOT TYPE-KUKA

MODEL	PART-NO.
KR5 ARC HW	91-3-0-41-7
KR16 ARC HW	91-3-0-41-12

FOR ROBOT TYPE-FANUC

MODEL	PART-NO.
ARC MATE 100iC / 100iC/6L	91-3-0-41-6
ARC MATE 120iC / 120iC/10L	91-3-0-41-8

FOR ROBOT TYPE-MOTOMAN

MODEL	PART-NO.
MA1400	91-3-0-41-3
MA1800	91-3-0-41-5
MA1900	91-3-0-41-4

DIVIDABLE CABLE BUNDLES

ALTERNATIVE



PARTS OF THE DIVIDABLE CABLE BUNDLE



CONNECTION FROM POWER SOURCE TO CONNECTION BRACKET

BEZEICHNUNG	PART-NO.
5 m	20-7-5
7 m	20-7-7
10 m	20-7-10
12 m	20-7-12
15 m	20-7-15

CONNECTION BRACKET

LENGTH	PART-NO.
Connection bracket	20-6-0-1

CONNECTION FROM CONNECTION BRACKET TO WIRE FEEDER PF5

LENGTH	PART-NO.
3 m	20-6-3
5 m	20-6-5
7 m	20-6-7

CABLE BUNDLE WITH SEPARATION BETWEEN POWER SOURCE AND WIRE FEEDER PF5

The moving parts of the cable bundle (next to the robot) are separated from the non-moving parts (power source). In case of maintenance work, only the moving parts have to be changed. The quick and easy replacement concept results in time and cost savings.

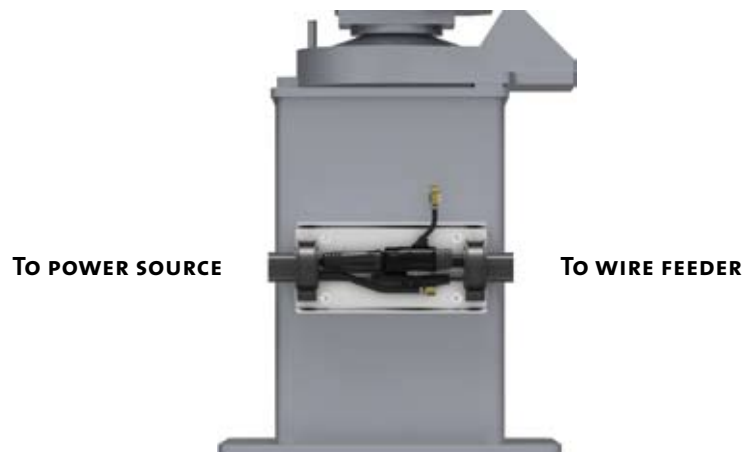

7

GROUND CABLE

**GROUND CABLE WITH 70 mm²
CONNECTOR AND CABLE PLUG**

Cables with larger diameters are available on request

OVERVIEW OF GROUND CABLES

LENGTH	PART-NO.
6 m	228078106
10 m	228078100
15 m	228078115
20 m	228078120

8

CONTROL CABLE

CONTROL CABLE: L-700/SPW-BUS

Standard control cable to connect the components:
Weld controller, power source, robot interface, wire
feeder.

OVERVIEW OF CONTROL CABLES

LENGTH	PART-NO.
0.5 m	541031050
1 m	541031001
2 m	541031002
3 m	541031003
5 m	541031005
7 m	541031007
10 m	541031000
12 m	541031012
15 m	541031015
20 m	541031020
25 m	541031025
30 m	541031030

PLUG & PLAY: CONTROL CABLE L-700

The advantages of a system concept are revealed by its details: One standard control cable (L-700) connects all system components (power source, robot interface, weld process controller and wire feeder) within the SKS welding system. The system is expandable: Other components, such as the water cooler WK5, can be integrated at any time into an existing system. New devices are automatically detected.

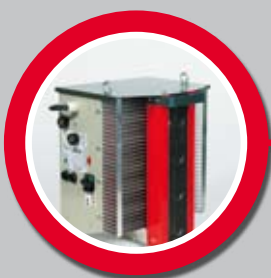
POWER SOURCE

ROBOT INTERFACE

WELD PROCESS CONTROLLER

WIRE FEEDER

The
Original.

Endless rotation with Power Joint™.

For all industrial robots
with inner cable dress.



Torch system Power Joint™

The **POWER JOINT™** torch system perfects the interaction of SKS welding machines and robots with inner cable dress. A single rotary joint with unlimited freedom of rotation transmits electrical energy and all media such as gas, air and wire. This reduces torch cable movement (no twisting/ no torsional strain) and therefore increases the lifetime of the torch cable. The lack of reorientations also saves airtime because the torch reaches every position in the shortest possible path.



THE COMPLETE SKS POWER JOINT™ WELD PACKAGE IS DESIGNED FOR THE FOLLOWING WELDING PROCESSES, MATERIALS AND POWER RANGE:

Processes: MIG/MAG (GMAW)

Materials: Fe, CrNi, Al, CuSi

Wire diameter: 0.8-1.6 mm

Max. power: 420 A - 60 % duty cycle/40 °C, air-cooled



POWER JOINT™ FOR ALL INDUSTRIAL ROBOTS WITH INNER CABLE DRESS

A single rotary joint with unlimited freedom of rotation transmits electrical energy and all media such as gas, air and wire. This reduces torch cable movement (no twisting/no torsional strain) and therefore increases the lifetime of the cable. The lack of reorientations also saves airtime because the torch reaches every position in the shortest possible path.

POWER JOINT™

DESCRIPTION	PART-NO.
Power Joint™	71-9-0

TECHNICAL DATA

Welding current	420 A - 60 % ED
Switch-Off automatic system	Deflection 10°
Reset accuracy	± 0.2 mm with TCP 400 mm
Weight	1.8 kg



MOUNTING KIT FOR POWER JOINT™

Kit includes: Fixing cover, connecting flange, clamping bush, sealing grommet and mounting material for the specific robot type

OVERVIEW OF MOUNTING KITS

FOR ROBOT TYPE-ABB

DESCRIPTION	PART-NO.
IRB1600 ID	71-9-0-3

FOR ROBOT TYPE-FANUC

DESCRIPTION	PART-NO.
ARC MATE 100iC / 100iC/6L / 120iC/10L	71-9-0-4
ARC MATE 120iC	71-9-0-6

FOR ROBOT TYPE-KUKA

DESCRIPTION	PART-NO.
KR5 ARC HW	71-9-0-5
KR16 ARC HW	71-9-0-8

FOR ROBOT TYPE-MOTOMAN (NX100 ROBOT-CONTROL)

DESCRIPTION	PART-NO.
MA1400 / MA1900	71-9-0-1
MA1800	71-9-0-2

**TORCH CABLE**

High flexible coaxial cable 72 mm² with Power Pin and Power Joint™ connector including switch-off cable for the robot

OVERVIEW OF TORCH CABLE

FOR ROBOT TYPE-ABB

DESCRIPTION	PART-NO.
IRB1600 ID	61-9-1800

FOR ROBOT TYPE-FANUC

DESCRIPTION	PART-NO.
ARC MATE 100iC	61-8-100
ARC MATE 100iC/6L	61-8-100-6
ARC MATE 120iC	61-8-120
ARC MATE 120iC/10L	61-8-120-10

FOR ROBOT TYPE-KUKA

DESCRIPTION	PART-NO.
KR5 ARC HW	61-9-5
KR16 ARC HW	

FOR ROBOT TYPE-MOTOMAN (NX100 ROBOT-CONTROL)

DESCRIPTION	PART-NO.
MA1400	61-9-1400
MA1800	61-9-1800
MA1900	61-9-1900

**LINER FOR TORCH CABLE**

For the following diameters and filler materials:

STEEL, BRONZE (WIRE-Ø 0.8 - 1.0 MM)

LENGTH	PART-NO.
1.8 m	415-35-6Q
3.0 m	415-35-10Q

STEEL, BRONZE (WIRE-Ø 1.2 - 1.6 MM)

LENGTH	PART-NO.
1.8 m	415-116-6Q
3.0 m	415-116-10Q

ALUMINUM (WIRE-Ø 1.0 - 1.6 MM) SLEEVE INCLUDED

LENGTH	PART-NO.
2.0 m	44-25-1016-20
3.5 m	44-25-1016-35

**SLEEVE FOR QUICK LOAD LINER**

Fixates the liner in the torch cable

SLEEVE FOR QUICK LOAD LINER

DESCRIPTION	PART-NO.
Sleeve for quick load liner	415-26



GOOSENECKS FOR POWER JOINT™

With the innovative bayonet lock system, the SKS gooseneck can be replaced quickly. This unique tool-free quick change system is also highly precise with TCP accuracy of ± 0.2 mm.

OVERVIEW OF GOOSENECKS

TYPE / TCP IN MM	PART-NO.
22° / 350	58-1-22-350-1
22° / 400	58-1-22-400-1
45° / 350	58-1-45-350-1
45° / 400	58-1-45-400-1
45° (ZK) / 400	58-1-245-400-1

SKS offers a special gooseneck (up to 250 A) for welding components with tight accessibility.

The special gooseneck needs a smaller insulator (ZK) and a more compact gas nozzle (ZK). Standard Power Lock contact tips can be used.

INFO

GOOSENECK



ZK-TYPE

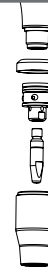

TCP drawings can be found on the last two pages (goose-necks).



CLAMPING CAP FOR SKS SINGLE WIRE GOOSENECKS

Tool-free assembly with bayonet quick-change system

CLAMPING CAP

DESCRIPTION	PART-NO.
Clamping cap	71-3-24



INSULATOR FOR SKS GOOSENECKS

OVERVIEW OF INSULATORS

DESCRIPTION	PART-NO.
Standard	58-1-5
ZK-type	43-6-4-2

**POWER LOCK: RETAINING HEADS**

Retaining heads for heavy duty applications with thread for threaded gas nozzles for simple and safe installation

OVERVIEW OF RETAINING HEADS

DESCRIPTION	PART-NO.
Standard	43-9-2
ZK-type	43-8-6

**POWER LOCK: CONTACT TIPS**

Tapered design for high TCP reproducibility

Improved heat transfer extends lifetime

Improved power transition: constant arc quality

OVERVIEW OF CONTACT TIPS (ALSO FOR ZK-TYPE)

WIRE-Ø	CU-ETP	CU-CRZR
0.8 mm	40-4-5-0.8E	40-4-7-0.8S
0.9 mm	40-4-5-0.9E	40-4-7-0.9S
1.0 mm	40-4-5-1.0E	40-4-7-1.0S
1.2 mm	40-4-5-1.2E	40-4-7-1.2S
1.4 mm	————	40-4-7-1.4S
1.6 mm	————	40-4-7-1.6S

**GAS NOZZLES**

Standard common gas nozzles with thread

PLEASE NOTE: An overview of gas nozzles with dimensions can be found on the last page.

OVERVIEW OF GAS NOZZLES (SHORT)

DESCRIPTION	PART-NO.
ø 16 mm, tapered	401-8-62-G
ø 13 mm, tapered	41-8-13-TS
ø 13 mm, bottle shaped	401-48-50-G
ø 16 mm, tapered, HD	401-81-62-G
ø 15 mm, bottle shaped (ZK)	41-8-115
ø 13 mm, bottle shaped (ZK)	41-8-113

OVERVIEW OF GAS NOZZLES (LONG)

DESCRIPTION	PART-NO.
ø 16 mm, tapered	401-4-62-G
ø 13 mm, tapered	401-4-50-G
ø 13 mm, bottle shaped	401-42-50-G
ø 16 mm, tapered, HD	401-6-62-G
ø 13 mm, tapered, HD	401-6-50-G

**POWER LOCK TOOL FOR CONTACT TIPS**

For replacement of contact tips: Fast exchange of contact tip without removing the gas nozzle

POWER LOCK CONTACT TIPS

DESCRIPTION	PART-NO.
Power Lock contact tip	51-9001-00

**PROGRAMMING TIPS**

Power Lock programming tips for precise seam programming

OVERVIEW OF PROGRAMMING TIPS

STICKOUT	PART-NO.
12 mm	65-6
15 mm	65-7
20 mm	65-8

TORCH 22°

PART-NO. 58-1-22-350-1

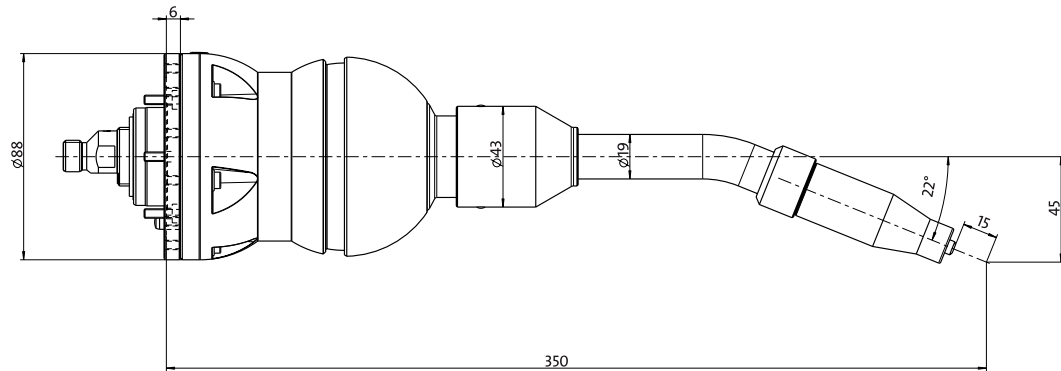

TORCH 22°

PART-NO. 58-1-22-400-1

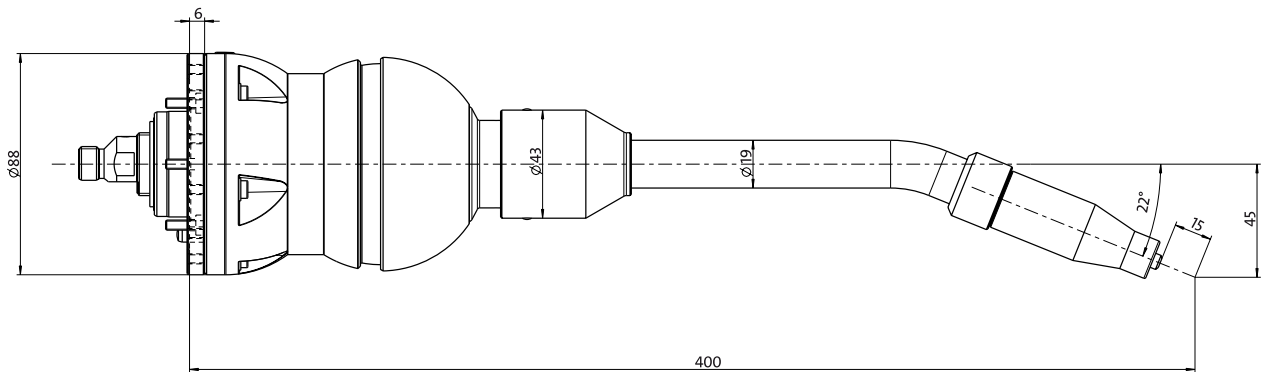

TORCH 45°

PART-NO. 58-1-45-350-1

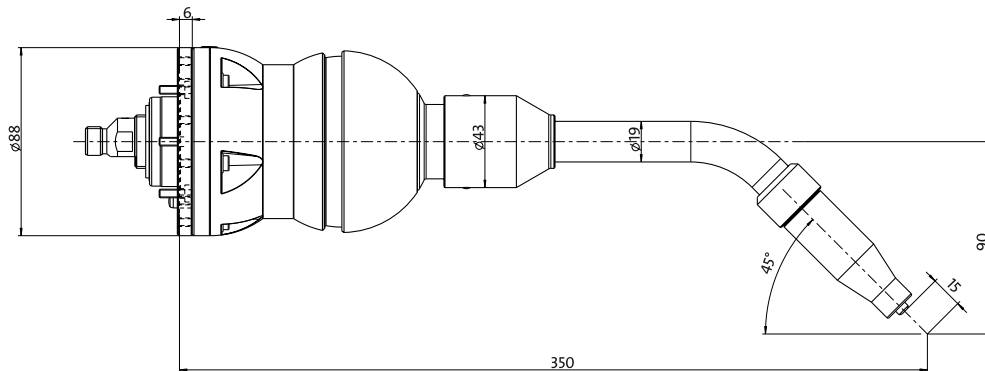

TORCH 45°

PART-NO. 58-1-45-400-1

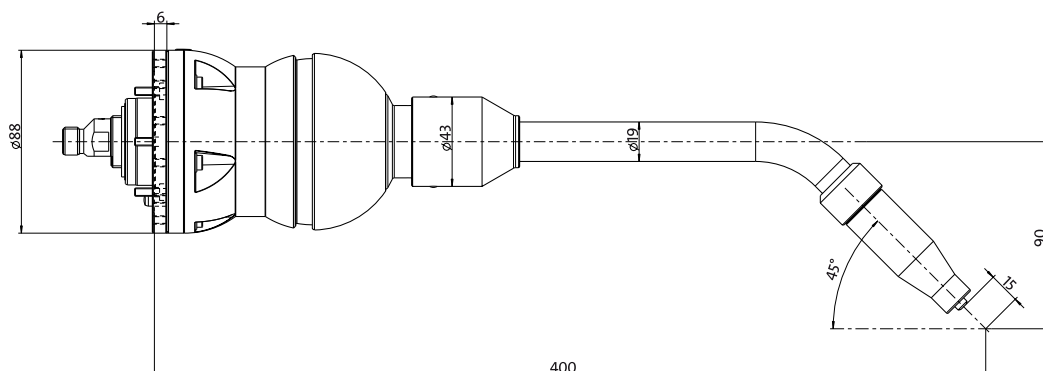

ZK TORCH 45°

PART-NO. 58-1-245-400-1

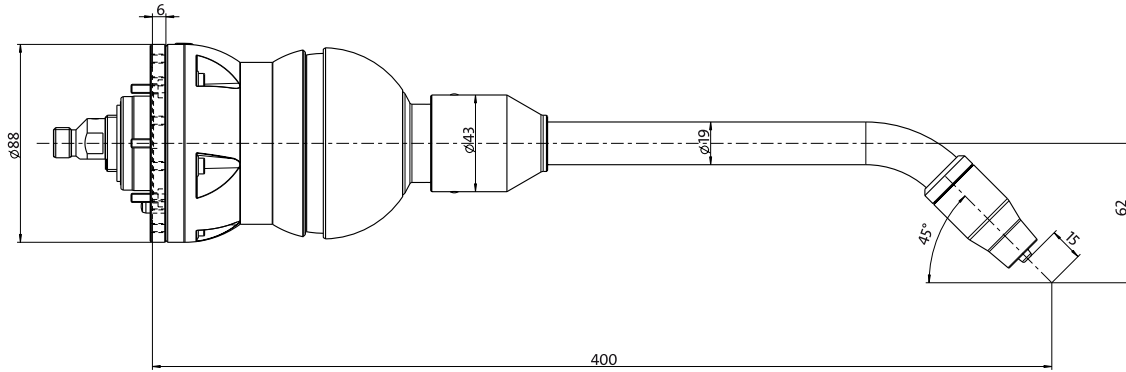

To check TCP of goosenecks and complete torch.

Checking fixtures are provided for all listed goosenecks with Power Joint™ torch system. Please contact us for detailed information.

Standard – type K (short)

Heavy Duty – type K (short)

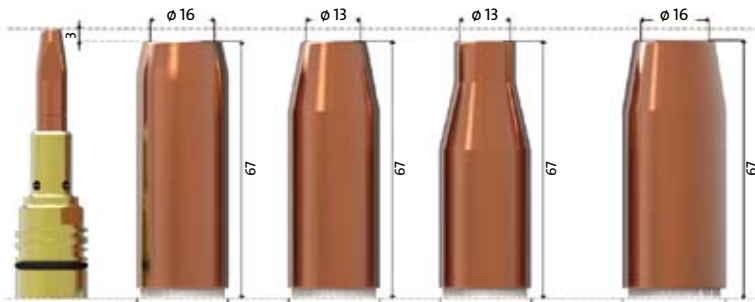

Standard – type ZK (short)

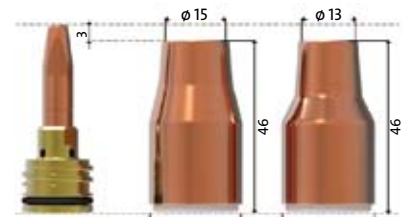

GAS NOZZLE PART-NO.:
CUTTERS (UNF3/8" x 24)
FOR GAS NOZZLES PART-NO.:

401-8-62-G	41-8-13-TS	401-48-50-G	401-81-62-G
66-3-13	66-3-16	66-3-16	66-3-13

41-8-115	41-8-113
66-3-12	66-3-17

Standard – type L (long)

Heavy Duty – type L (long)

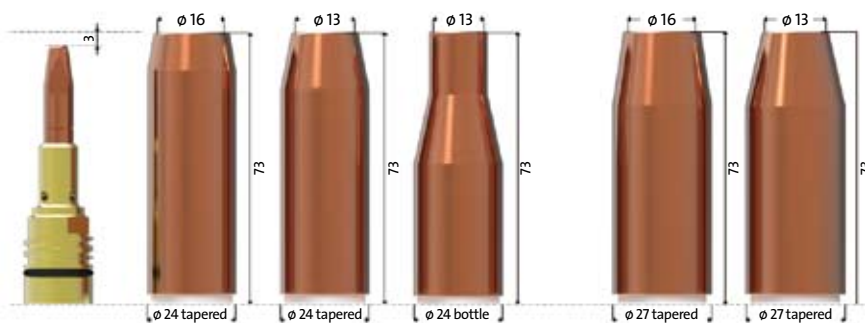

GAS NOZZLE PART-NO.:
CUTTERS (UNF3/8" x 24)
FOR GAS NOZZLES PART-NO.:

401-4-62-G	401-4-50-G	401-42-50-G	401-6-62-G	401-6-50-G
66-3-14	66-3-15	66-3-15	66-3-14	66-3-15

PLEASE NOTE: With long gas nozzles the contact tip is recessed 3 mm.



www.sks-welding.com

SKS Welding Systems GmbH | Austrasse 2a | 66849 Landstuhl | Germany | Phone +49(0)6371/9267-0 | Fax +49(0)6371/9267-19

Subject to change.